

PARABODY INC.



EX350 PEC DEC ATTACHMENT
PBF353

PRODUCT ASSEMBLY
INSTRUCTION SHEETS

- TOOLS REQUIRED FOR ASSEMBLY:
- * 1/2 INCH SOCKET
 - * 9/16 INCH SOCKET
 - * ADJUSTABLE WRENCH
 - * HAMMER
 - * RUBBER MALLET

REVISION: J

If you experience any problems with the assembly of this product, please contact your dealer or your PARABODY Customer Service representative at:
1-800-328-9714.

CASH NO.	DESCRIPTION
AS SHOWN	

REV	DESCRIPTION	CHG NO.	APP'D.	DATE
A	NEW RELEASE	P8102		
B	2HP PULLEY QUANTITIES	1435		1/1/14

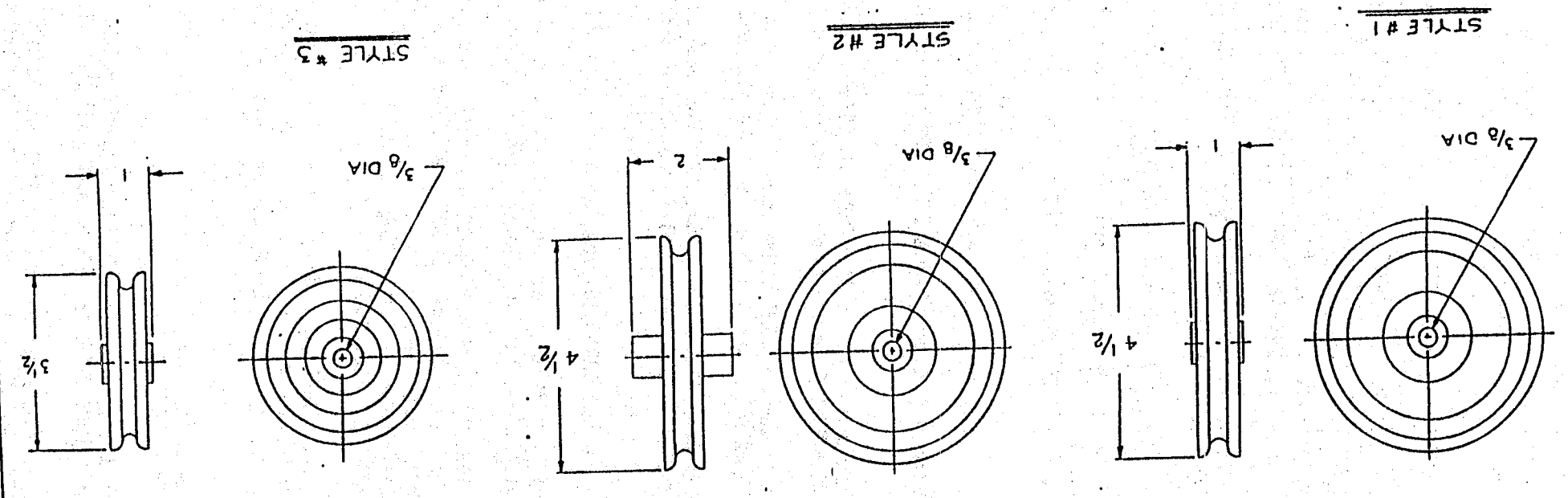

This drawing has been provided to assist you in identifying the three styles of pulleys used on this product and the required quantity used in each assembly step.

STYLE #	DESCRIPTION	TOTAL QTY	MAIN UNIT	PEC DEC UNIT
1	3/8 DIA. X 1 IN. LG. BUSHING PULLEY	7	5	2
2	3/8 DIA. X 2 IN. LG. BUSHING PULLEY	3	3	0
3	3/8 DIA. X 1 IN. LG. BUSHING PULLEY	3	3	0

Parabody, Inc.
RAMSEY, MINNESOTA

TOLERANCES UNLESS OTHERWISE SPECIFIED

ANGULAR	~
FRACTIONAL	~
DECIMAL	~

SCALE 1/2" = 1"
SHEET 1 OF 1
DRAWING NO. PB2055

TITLE: PULLEY I.D. SHEET
EX350

DATE: 1/1/14
BY: [Signature]

PBF353 EX350 PEC DEC ATTACHMENT ASSEMBLY

THE INSTRUCTIONS ARE TO BE USED WITH PEC DEC DRAWING SHEET #1

1. Put two (2) 2 in. sq. END CAPS into ends of square tube of BEARING HOUSING.

2. To bolt BEARING HOUSING and PULLEY BRACKET SUPPORT to MAIN UPRIGHT ASSEMBLY, discard two (2) PAINTED CONNECTOR BRACKETS. Using the two (2) 1/2 x 3-1/2 in. HEX HEAD BOLTS, four (4) 1/2 in. FLAT WASHERS, two (2) 1/2 in. LOCK WASHERS and two (2) 1/2 in. NUTS. ATTACH BEARING HOUSING AND PULLEY BRACKET SUPPORT ON EITHER SIDE OF ASSEMBLED MAIN UPRIGHT. UPRIGHT TOP AND BOTTOM SECTION SHOULD FIT TIGHT TOGETHER. TIGHTEN ONLY UNTIL SNOG. NOTE: THE GREEN DOT, LOCATED ON THE PULLEY BRACKET SUPPORT, SHOULD MATCH UP WITH THE GREEN DOT ON THE MAIN UPRIGHT BOTTOM SECTION.

* NOTE: IF THIS UNIT IS BEING ASSEMBLED WITH THE BASE UNIT, STOP HERE AND RETURN TO STEP #16 OF THE BASE UNIT INSTRUCTIONS.

3. LOOSELY bolt two (2) 4-1/2 in. dia PULLEYS with 1 in. bushing, to the PULLEY BRACKET SUPPORT using two (2) 3/8 x 1-3/4 in. HEX HEAD BOLTS, two (2) CABLE RETAINING "L" CLIPS, two (2) 3/8 in. LOCK WASHERS and two (2) 3/8 in. NUTS. NOTE: DO NOT TIGHTEN.

4. Insert one (1) 3/4 in. I.D. FLANGE BEARING into each of four (4) open ends of the BEARING HOUSING.

5. Press four (4) 2 in. sq. END CAPS into open ends of LEFT and RIGHT ARMS.

6. Insert pivot of each arm into FLANGE BEARINGS and secure with two (2) STARLOCK COLLARS.

7. Peel off backing from two (2) 1 in. PLASTIC STOPS, attach to angle iron stop bracket on BEARING HOUSING where arm cams make contact.

8. Bolt SEAT FRAME to MAIN UPRIGHT using two (2) 3/8 x 3 in. HEX HEAD BOLT, four (4) 3/8 in. FLAT WASHERS, two (2) 3/8 in. LOCK WASHERS and two (2) 3/8 in. NUTS.

9. Bolt BACK PAD to MAIN UPRIGHT using two (2) 3/8 x 3 in. HEX HEAD BOLTS, two (2) 3/8 in. FLAT WASHERS and two (2) 3/8 in. LOCK WASHERS. (HIDDEN WELT CLIP SHOULD BE FACING DOWN)

10. Insert one (1) 1-3/4 in. END CAP into open end of SEAT FRAME.

11. Bolt SEAT PAD to SEAT FRAME using two (2) 3/8 x 2-3/4 in. HEX HEAD BOLTS, two (2) 3/8 in. FLAT WASHERS and two (2) 3/8 in. LOCK WASHERS.

12. Slide LARGE FOAM ROLLER PADS onto LEFT and RIGHT ARMS.
NOTE: If a lubricant is required, RUBBING ALCOHOL thoroughly coating the inside of the grip is the best material to use.

NOTE: BEFORE PROCEEDING WITH CABLE INSTALLATION, UNRAVEL CABLE, AND REMOVE AS MUCH SPIRALING AS POSSIBLE.

13. To attach the two (2) CABLES. Bolt one end of the cables to the cams at the hole near the square tube using two (2) 5/16 x 1 in. HEX HEAD BOLT, four (4) 5/16 in. FLAT WASHERS, two (2) 5/16 in. LOCK WASHERS and two (2) 5/16 in. NUTS. (SEE DETAIL C)

14. After bolting cables to cams, pull cables over pulleys mounted to the PULLEY BRACKET SUPPORT. (SEE DETAIL A).

Place cable in pulley groove and TIGHTEN PULLEY BOLTS. (NOTE: BE SURE CABLE RETAINING "L" CLIPS ARE OVER IN THE GROOVE AND STRAIGHT UP!)

15. Join the two cables together by one (1) 1/4 in. QUICK LINK and attach to the 5/16 in. SNAP HOOK, which is attached to 24 LINK CHAIN on the LOW ROW SWIVEL

PBF353 EX350 PEC DEC ATTACHMENT ASSEMBLY PARTS LIST

SOFT AND COUNT ALL PARTS BEFORE BEGINNING ASSEMBLY

ITEM	NAME/DESCRIPTION	QTY
1	5/16 X 1 HEX HEAD BOLT	2
2	5/16 FLAT WASHER	4
3	5/16 LOCK WASHER	2
4	5/16 NUT	2
5	3/8 X 1-3/4 HEX HEAD BOLT	2
6	3/8 X 2-3/4 HEX HEAD BOLT	2
7	3/8 X 3 HEX HEAD BOLT	4
8	STARLOCK COLLAR	2
9	3/4 IN. I.D. FLANGE BEARING	4
10	3/8 FLAT WASHER	8
11	3/8 LOCK WASHER	8
12	3/8 NUT	4
13	1 IN. PLASTIC STOP	2
14	CABLE RETAINING "L" CLIP	2
15	1-3/4 IN. SQ. END CAP	1
16	2 IN. SQ. END CAP	6
17	1/4 IN. QUICK LINK	1

ITEM	NAME/DESCRIPTION	QTY
1	CABLES	2
2	BEARING HOUSING	1
3	SEAT FRAME	1
4	LEFT PEC DEC ARM	1
5	RIGHT PEC DEC ARM	1
6	BACK PAD	1
8	SEAT PAD	1
9	LARGE FOAM ROLLER PAD	2
10	4-1/2 DIA. X 1 IN. BUSHING PULLEY	2
11	PULLEY BRACKET SUPPORT	1

NOTE: BOLT LENGTH IS MEASURED FROM THE UNDERSIDE OF THE HEAD OF THE BOLT.

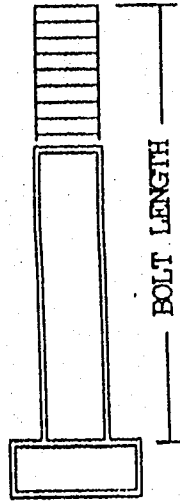

BOLT LENGTH RULER:

